

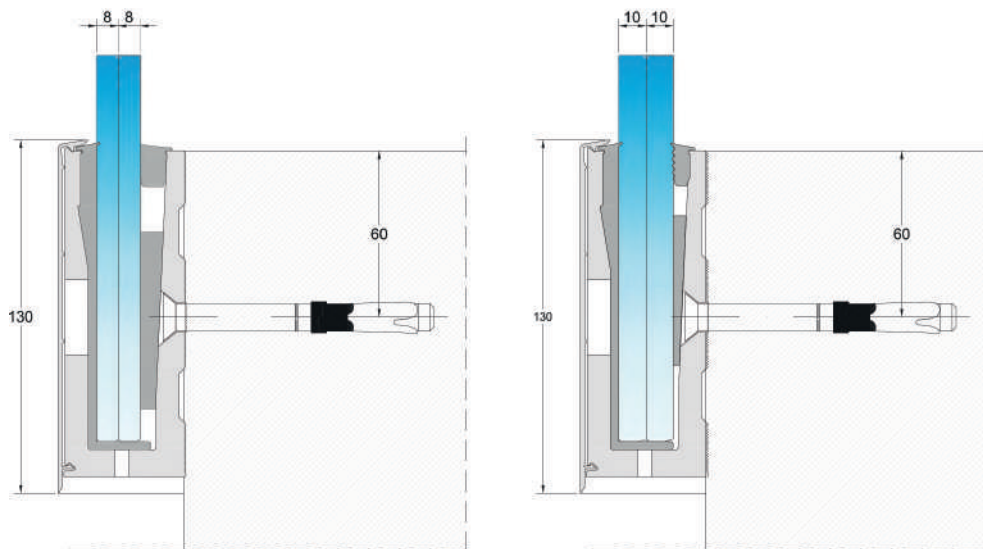

**GUARDA-CORPOS
GARDE-CORPS
GLASS RAILING SYSTEM**

GUARDA-CORPOS GARDE-CORPS GLASS RAILING SYSTEM

- > Segurança | Sécurité | Security
- > Elegância | Élégance | Elegance
- > Linhas minimalistas | Lignes minimalistes | Minimalist lines



ENSATEC

Serviço acreditado por ENAC Organismo de Notificação N° 1668. | Service accrédité pour ENAC Organisme de Notification N° 1668.
Service accredited for ENAC Organization of the Notification N° 1668.



DB SE-AE

Parágrafo 3.2 das ações de reforço
Paragraphe 3.2 des actions de renforcement
Section 3.2 of the reinforcement actions

Preenchido
Remplie | Filled

Doc n°: 237155
Obras privadas | Œuvres privés | Private works:
10+10 laminado | feuilleté | laminated
Doc n°: 237993
Obras privadas | Œuvres privés | Private works:
10+10 laminado | feuilleté | laminated
Doc n°: 237153
Obras privadas | Œuvres privés | Private works:
8+8 temperado-laminado | feuilleté-trempé | soaked laminated glass



Teste estático horizontal para o exterior

Test statique horizontal vers l'extérieur
Horizontal static test outwards
UNE-EN-85-238-91

Preenchido
Remplie | Filled



Teste estático horizontal para o interior

Test statique horizontal vers l'intérieur
Horizontal static test inward
UNE-EN-85-238-91

Preenchido
Remplie | Filled



Teste estático vertical

Test statique vertical
Vertical static test
UNE-EN-85-238-91

Preenchido
Remplie | Filled



Teste dinâmico de corpo rígido

Test dynamique de corps mou de grandes dimensions
Hard body dynamic test
UNE-EN-85-238-91

Preenchido
Remplie | Filled



Teste dinâmico de corpo rígido

Test dynamique de corps dur
Hard body dynamic test
UNE-EN-85-238-91

Preenchido
Remplie | Filled



Teste de segurança

Test de sécurité
Security test
UNE-EN-85-238-91

Preenchido
Remplie | Filled

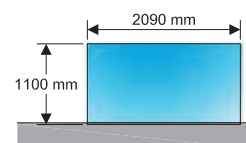

Doc n°: 237156
Obras privadas | Œuvres privés | Private works:
10+10 temperado-laminado | feuilleté-trempé | soaked laminated glass
Doc n°: 238005
Obras privadas | Œuvres privés | Private works:
10+10 laminado | feuilleté | laminated
Doc n°: 237154
Obras privadas | Œuvres privés | Private works:
8+8 temperado-laminado | feuilleté-trempé | soaked laminated glass

Todas as indicações mencionadas neste catálogo (características, dimensões, informações, ...) estão sujeitas a alterações e, portanto, não podem constituir um compromisso da nossa parte.
Toutes les indications mentionnées sur le présent catalogue (caractéristiques, côtes, informations,...) sont susceptibles de modifications, elles ne peuvent donc constituer un engagement de notre part.
All the indications mentioned on this catalog (characteristics, dimensions, informations, ...) are subject to change, they cannot therefore constitute a commitment on our part.

GUARDA-CORPOS GARDE-CORPS GLASS RAILING SYSTEM

- > Segurança | Sécurité | Security
- > Elegância | Élégance | Elegance
- > Linhas minimalistas | Lignes minimalistes | Minimalist lines

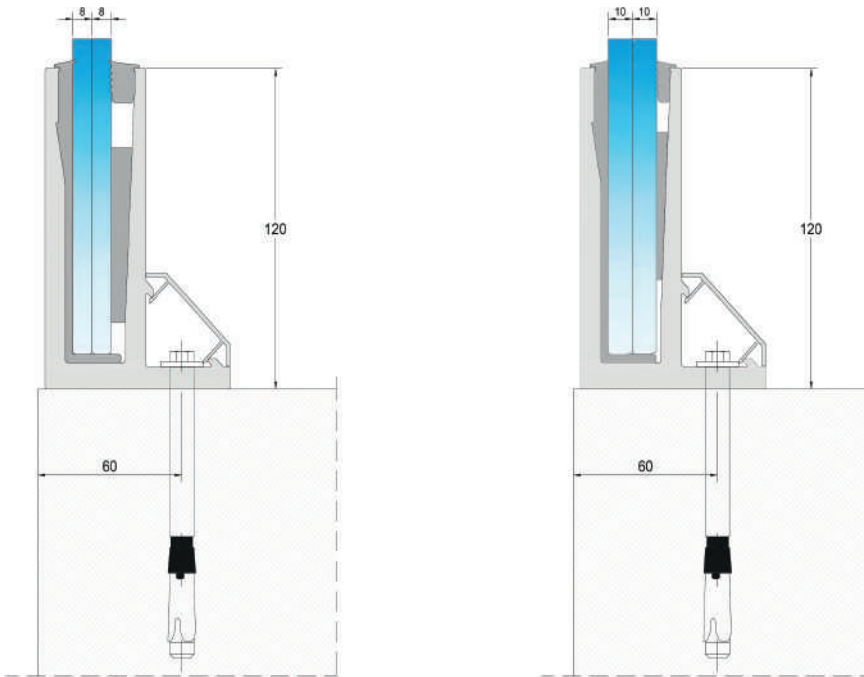

ENSATEC

Serviço acreditado por ENAC Organismo de Notificação N° 1668. | Service accrédité pour ENAC Organisme de Notification N° 1668.
Service accredited for ENAC Organization of the Notification N° 1668.



DB SE-AE

Parágrafo 3.2 das ações de reforço
Paragraphe 3.2 des actions de renforcement
Section 3.2 of the reinforcement actions

Preenchido
Remplie | Filled

Doc n°: 237155
Obras privadas | Œuvres privés | Private works:
10+10 laminado | feuilleté | laminated
Doc n°: 237993
Obras privadas | Œuvres privés | Private works:
10+10 laminado | feuilleté | laminated
Doc n°: 237153
Obras privadas | Œuvres privés | Private works:
8+8 temperado-laminado | feuilleté-trempe | soaked laminated glass



Teste estático horizontal para o exterior

Test statique horizontal vers l'extérieur
Horizontal static test outwards
UNE-EN-85-238-91

Preenchido
Remplie | Filled



Teste estático horizontal para o interior

Test statique horizontal vers l'intérieur
Horizontal static test inward
UNE-EN-85-238-91

Preenchido
Remplie | Filled



Teste estático vertical

Test statique vertical
Vertical static test
UNE-EN-85-238-91

Preenchido
Remplie | Filled



Teste dinâmico de corpo rígido

Test dynamique de corps mou de grandes dimensions
Hard body dynamic test
UNE-EN-85-238-91

Preenchido
Remplie | Filled



Teste dinâmico de corpo rígido

Test dynamique de corps dur
Hard body dynamic test
UNE-EN-85-238-91

Preenchido
Remplie | Filled



Teste de segurança

Test de sécurité
Security test
UNE-EN-85-238-91

Preenchido
Remplie | Filled

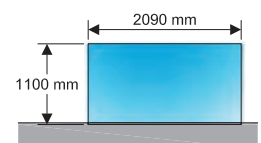

Doc n°: 237156
Obras privadas | Œuvres privés | Private works:
10+10 temperado-laminado | feuilleté-trempe | soaked laminated glass
Doc n°: 238005
Obras privadas | Œuvres privés | Private works:
10+10 laminado | feuilleté | laminated
Doc n°: 237154
Obras privadas | Œuvres privés | Private works:
8+8 temperado-laminado | feuilleté-trempe | soaked laminated glass

Todas as indicações mencionadas neste catálogo (características, dimensões, informações, ...) estão sujeitas a alterações e, portanto, não podem constituir um compromisso da nossa parte.
Toutes les indications mentionnées sur le présent catalogue (caractéristiques, côtes, informations,...) sont susceptibles de modifications, elles ne peuvent donc constituer un engagement de notre part.
All the indications mentioned on this catalog (characteristics, dimensions, informations, ...) are subject to change, they cannot therefore constitute a commitment on our part.

GUARDA-CORPOS GARDE-CORPS GLASS RAILING SYSTEM

- > Segurança | Sécurité | Security
- > Elegância | Élégance | Elegance
- > Linhas minimalistas | Lignes minimalistes | Minimalist lines

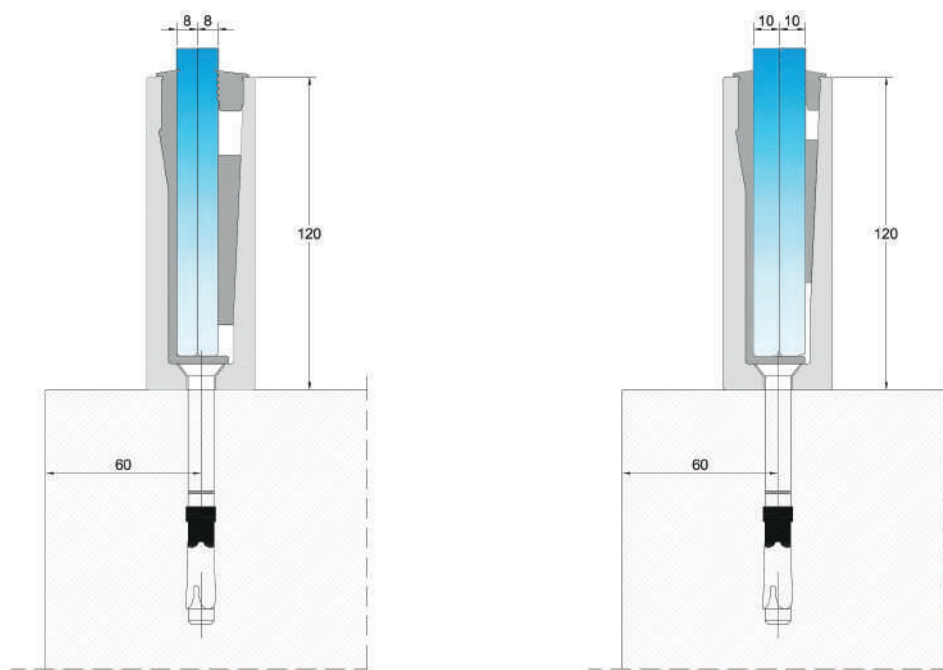

ENSATEC

Serviço acreditado por ENAC Organismo de Notificação N° 1668. | Service accrédité pour ENAC Organisme de Notification N° 1668.
Service accredited for ENAC Organization of the Notification N° 1668.



DB SE-AE

Parágrafo 3.2 das ações de reforço
Paragraphe 3.2 des actions de renforcement
Section 3.2 of the reinforcement actions

Preenchido
Remplie | Filled

Doc n°: 237155
Obras privadas | Œuvres privés | Private works:
10+10 laminado | feuilleté | laminated
Doc n°: 237993
Obras privadas | Œuvres privés | Private works:
10+10 laminado | feuilleté | laminated
Doc n°: 237153
Obras privadas | Œuvres privés | Private works:
8+8 temperado-laminado | feuilleté-trempe | soaked laminated glass



Teste estático horizontal para o exterior

Test statique horizontal vers l'extérieur
Horizontal static test outwards
UNE-EN-85-238-91

Preenchido
Remplie | Filled



Teste estático horizontal para o interior

Test statique horizontal vers l'intérieur
Horizontal static test inward
UNE-EN-85-238-91

Preenchido
Remplie | Filled



Teste estático vertical

Test statique vertical
Vertical static test
UNE-EN-85-238-91

Preenchido
Remplie | Filled



Teste dinâmico de corpo rígido

Test dynamique de corps mou de grandes dimensions
Hard body dynamic test
UNE-EN-85-238-91

Preenchido
Remplie | Filled



Teste dinâmico de corpo rígido

Test dynamique de corps dur
Hard body dynamic test
UNE-EN-85-238-91

Preenchido
Remplie | Filled



Teste de segurança

Test de sécurité
Security test
UNE-EN-85-238-91

Preenchido
Remplie | Filled

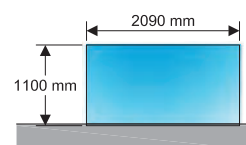

Doc n°: 237156
Obras privadas | Œuvres privés | Private works:
10+10 temperado-laminado | feuilleté-trempe | soaked laminated glass
Doc n°: 238005
Obras privadas | Œuvres privés | Private works:
10+10 laminado | feuilleté | laminated
Doc n°: 237154
Obras privadas | Œuvres privés | Private works:
8+8 temperado-laminado | feuilleté-trempe | soaked laminated glass

Todas as indicações mencionadas neste catálogo (características, dimensões, informações, ...) estão sujeitas a alterações e, portanto, não podem constituir um compromisso da nossa parte.
Toutes les indications mentionnées sur le présent catalogue (caractéristiques, côtes, informations,...) sont susceptibles de modifications, elles ne peuvent donc constituer un engagement de notre part.
All the indications mentioned on this catalog (characteristics, dimensions, informations, ...) are subject to change, they cannot therefore constitute a commitment on our part.